



OWNER'S GUIDE USE AND CARE MANUAL



DUCTED COOLER MODELS:

PD4803 PD6803
PH4803 PH6803

- | | |
|----------------|--------------------|
| * Safety | * Operation |
| * Installation | * Maintenance |
| * Start-up | * Trouble Shooting |

Congratulations: You have purchased a product of superior performance and design, which will give the best service when properly installed, operated and maintained.

This guide will provide you with information needed to mount, operate, inspect, maintain, and troubleshoot your evaporative air cooler.

The first section, Installation and Start-Up, gives details for installation. The second section, Maintenance, contains operational and maintenance instructions, while Troubleshooting includes information on commonly encountered problems.

INSTALLER: Please deliver this guide to owner.

⚠ WARNING - TO REDUCE THE RISK OF FIRE, ELECTRIC SHOCK, OR INJURY TO PERSONS, OBSERVE THE FOLLOWING.

READ AND SAVE THESE IMPORTANT SAFETY INSTRUCTIONS.

- Read all instructions carefully before installation.
- Use only the blower motor and circulating pump(s) combinations marked on the Model Nameplate indicating suitability for use in this model. Any other motors or pumps cannot be substituted.
- Installation work and electrical wiring must be done by qualified person(s) in accordance with all applicable codes and standards, including fire rated construction.
- When cutting or drilling into a wall or ceiling, do not damage electrical wiring or other concealed utilities (water or gas lines, sewer lines, etc.).
- Cooler motor, pump, cabinet and junction box must be grounded in accordance with all local and national codes. A ground wire must be used between the power supply and the cooler.
- Be sure that the cooler is connected to proper line voltage stamped on the pump and blower (fan) motor specification plate. NOTE: Improper voltage will void the pump and/or motor warranties and may cause serious personal injury or property damage.
- Do not operate this blower (fan) motor with any solid-state speed control device.

- Always disconnect electrical power to unit before working on or servicing cooler. More than one disconnect switch may be required to de-energize the equipment for servicing.
- Do not remove access panels while cooler is running, this may cause the blower (fan) motor to overload and damage the motor windings.

NOTE:

- Do not locate unit near exhaust or vent pipes as odors or fumes may be drawn into cooler.
- Use of anode devices, chemical additives or treatments in this cooler will void the warranty.
- Your warranty does not cover shipping damage. Report all shipping damage at once to dealer or carrier making the delivery.
- For future reference, record the model and serial numbers, date and place of purchase of your evaporative cooler here:

Model # _____

Serial # _____

Date of Purchase: _____

Place of Purchase: _____

INTRODUCTION

Your Pro-series evaporative air cooler was thoroughly tested and inspected before leaving the factory. This manual is your guide to proper installation procedures along with information about reasonable care and maintenance that will ensure safe, economical and trouble free cooling. Failure to follow these instructions may damage your cooler, impair its operation, create the potential for serious personal injury and/or void the warranty. **Read it carefully.**

Installation normally involves the connection of the blower opening to a duct system or to a short duct with a ceiling diffuser. For an installation in an existing building, modifications may be necessary. If installation is being done by someone other than a professional HVAC contractor, it is suggested that the installation be thoroughly discussed with a professional person familiar with cooler installation. Don't attempt to perform any part of the installation described in this manual unless you are **fully qualified** to do so.

Carefully read the contents of this manual before beginning the installation process.

CAUTION: All mechanical, plumbing and electrical installations must comply with local and national building and safety codes, and must be performed by qualified personnel only.

NOTE - References in this manual to local or national codes means that those items must comply with applicable installation codes as specified by the building code authority having jurisdiction at the installation location. It is the installer's duty to comply with all building code requirements.

Before attempting to install the cooler, confirm that the following preparations have been made:

- Verify that the supporting surface is strong enough to bear the weight of the cooler when in use; remember that when the system fills with water, the cooler will be much heavier than when dry.
- Make sure you have adequate resources for lifting the cooler.
- Check the electric power supply to see that it matches the requirements shown on the model and motor nameplates.
- Verify that the supporting surface is level in all directions; this is necessary to ensure proper distribution of water into the pad, maximizing cooling performance.
- Confirm that any planned ductwork and electrical supply installation needs comply with local and national codes.
- For ease of installation you can separate the wet section from the blower section by removing the 4 bolts. Unplug the pump and drain pump before separating the sections.

Model Number	Operating Weight (lbs.)
PD / PH 4803	190
PD / PH 6803	220

Location

Your cooler may be a down (PD) or horizontal (PH) discharge model. Down discharge coolers are designed for installation on either flat or pitched roofs (see Fig. 1). Horizontal discharge coolers are designed for installation on the side of a building, ground level installation when mounted on a slab or, using a 90-degree transition duct, on a flat or pitched roof (see Fig. 2). Evaporative air-cooling systems (down or side discharge) can be connected to a duct distribution system with outlet registers for each area to be cooled.

Install coolers in a location where only fresh outside air can enter the cooling system. Avoid installing units in closed-in areas, such as an attic or storeroom, which restricts free air movement around and into the cooler, or near vent pipes, kitchen exhaust, etc.; as obnoxious odors or fumes may be drawn into unit.

NOTE: When coolers are installed within the jurisdiction of the City of Los Angeles (C.O.L.A.) Building codes, they can only be installed on the outside of buildings.

Air Exhausting / Maximum Cooling

Evaporative air coolers will function correctly only if there is a way for the cooled air to exit the building. Windows, vents, doors or other exhaust openings at a point most distant from cooled air inlet should be open to permit free movement of air out of the area being cooled, and to avoid building up excessive pressure inside the space. Proper location of exhaust openings is important as they guide flow of air through areas where cooling is desired.

Since coolers function best when there is plenty of exhaust air, you can leave doors or windows open so your house can breathe. To get the maximum capacity of your cooler, and to help keep insects, dust, dirt, etc out of the cooled space, the building/space should be maintained at a slightly positive air pressure (airflow going into the building should be slightly more than the air that is leaving).

How much should you open your windows? You should open your windows until the air pressure inside the house is nearly balanced with the air outside. One method used to determine when the air is reasonably balanced is to place a tissue paper against the screen in the window furthest from the cooler and adjust the opening of the other windows in the house until the tissue paper stays lightly on the screen. This is usually about 2 square feet of opening per 1000 cfm of air produced by the cooler. You can adjust different windows in the house to direct the most airflow to the areas that are occupied during different times of the day or night (example: living room windows during the daytime, bedroom windows at night.)

To eliminate a rush of warm air when starting the cooler be sure to turn on the pump for a few minutes to completely wet out the pads before turning the blower on.

Duct System

Air can be delivered over a distance to individual rooms or areas by means of a duct system. The duct system, which is tailored to fit the building, should be designed, fabricated and installed by a competent HVAC sheet metal contractor, preferably while building is under construction.

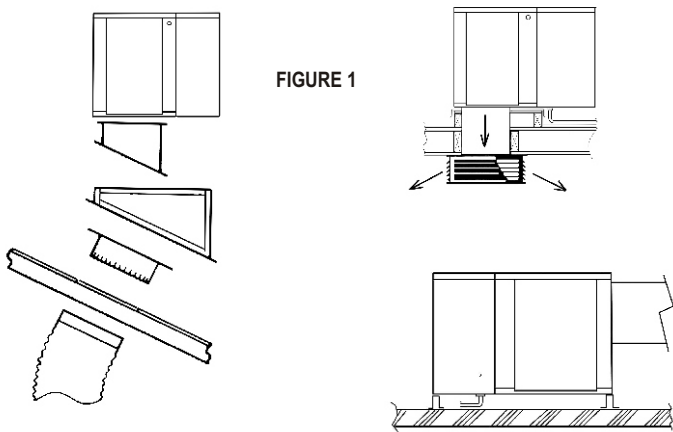

FIGURE 1

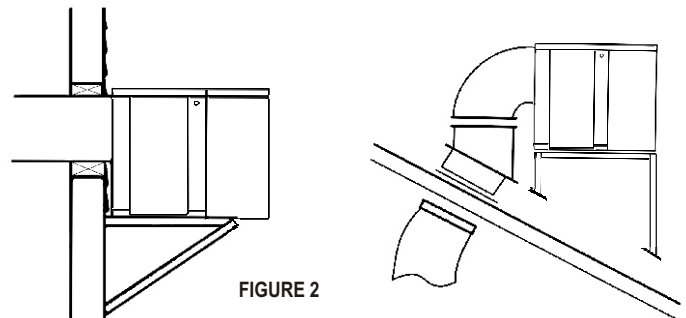

FIGURE 2

INSTALLATION

CAUTION: All electrical installations must comply with local and national building & safety codes; all work must be performed by qualified personnel only.

CAUTION: Disconnect all electrical power to the cooler before attempting to install, open, or service your cooler. If the cooler is thermostatically controlled, the thermostat must not be used as the power supply disconnect, as it may reset and start the unit unexpectedly.

CAUTION: If the cooler is supported by legs attached to each corner, the middle of the cabinet where the two sections join must be supported as well.

CAUTION: Do not screw or drill within 6 inches of the bottom of the wet section of the cooler, you could puncture the plastic water reservoir.

WARNING: Pump receptacles are for grounded evaporative cooler pumps only. Do not plug any other electrical equipment into the receptacles.

Even while routinely inspecting or servicing the inside, the cooler can be accidentally started. Keep all personnel away from the cooler and electrical supply when you are working on it. Before servicing or cleaning unit, switch power off at the service disconnects. Do not turn power to unit on until installation or service work is complete.

For maximum safety, make sure cooler cabinet, blower motor and pump are properly grounded to a suitable ground connection as required by all local and national codes.

Electrical Installation

THIS COOLER IS PRE-WIRED FOR 115 VOLT , 60 Hz POWER ONLY.

NOTE: Improper voltage connections will void all warranties.

Mount Weatherproof Disconnect Switch Box

Located inside the parts box are the items required to mount the switch box to the cooler. Mount the switch box as follows:

1. From inside of the cabinet (8), insert chase nipple (1) thru 7/8" hole and fasten it tightly to the cabinet with the conduit jam nut (2).
2. Screw the switch box (3) onto the chase nipple (1) until tight and box is aligned vertically.
3. Insert the power supply wires from circuit board thru chase nipple into switch box.

Connect Power Supply

CAUTION: The external power supply to the unit must be adequately grounded and protected against overloads and short circuits per all national and local codes.

Run power supply to disconnect switch box and connect to the poles of the switch (4). Refer to the wiring diagram on the control box cover to complete the electrical installation of your cooler. Secure the switch into the box and install the gasket and switch cover (5).

Thermostat Cable Installation

The thermostat for this cooler is connected to the control panel by means of a thermostat cable (6 conductor minimum, not provided). Type CL2, 18 or 20 gauge, UL Listed thermostat wire is recommended.

- 1) Route one end of the thermostat cable (6) through the 1/2" hole in the corner post on the left side of the access door and then through the 1/2" hole in the left end of the control box.
- 2) Insert the individual conductors of the thermostat cable (6) into the terminal block connections (9) on the left side of the printed circuit board. Connect colored wires to terminals as follows:

White to 'C'	Brown to 'H'	Red to 'L'
Green to 'P'	Yellow to 'D'	Blue to 'R'

Tighten screws carefully.

- 3) Install strain relief bushings (7) over the thermostat cable into the 1/2" holes in the corner post and control box, allowing a slight amount of slack - do not stretch the thermostat cable tight. Replace the control box cover and tighten the 4 screws.
- 4) Select a location for the thermostat:
 - Mount the thermostat about 5 to 6 feet above the floor.
 - Mount the thermostat on an interior wall, not on an outside wall.
 - Do not mount near sources of heat or in direct sunlight.
 - Do not mount in the direct draft from cooler air registers.
 - Avoid dead air spaces which have little air circulation.
- 5) Install the thermostat using the "Mounting Instructions for Thermostat" furnished with the cooler.

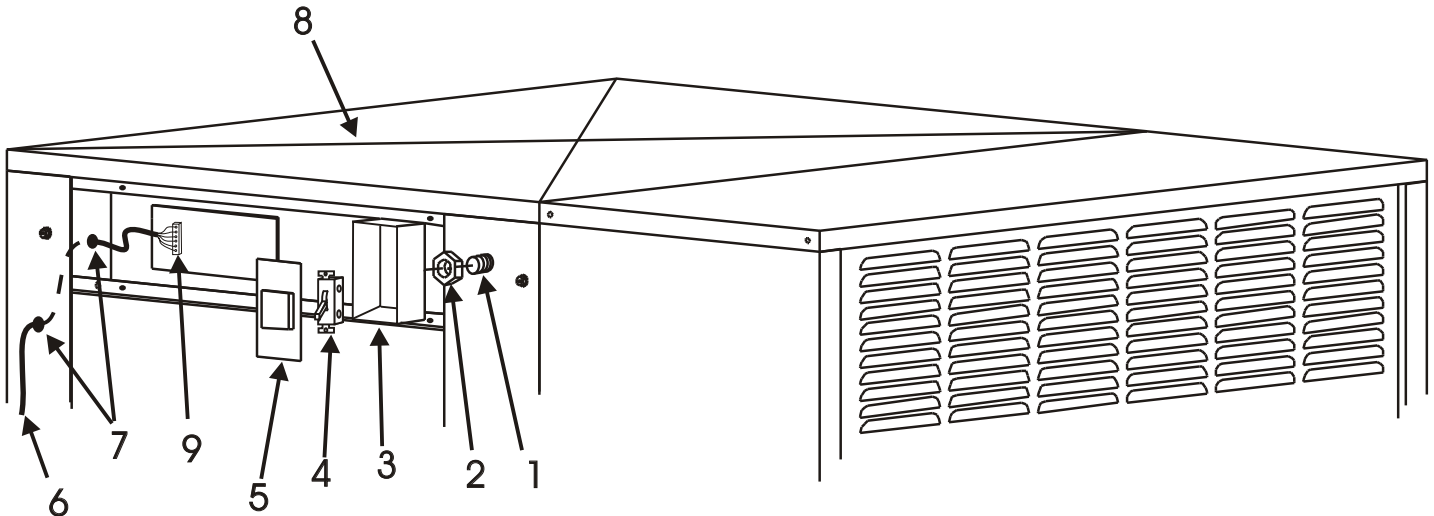

- | | | | | |
|---------------------|---------------------------|-------------------|--|-----------------------|
| 1) Chase Nipple | 2) Jam Nut | 3) Junction Box | 4) Disconnect Switch | 5) Junction Box Cover |
| 6) Thermostat Cable | 7) Strain Relief Bushings | 8) Cooler Cabinet | 9) Terminal Block for Thermostat Cable | |

Belt Tension Adjustment

CAUTION: Disconnect all electrical power to the cooler and insure that belt is not rotating before adjusting belt tension. Do not adjust belt tension by changing diameter of motor pulley. Adjust belt tension only by adjusting motor bracket.

Correct belt tension and alignment is important, proper setup reduces power consumption and prolongs life of belt and motor. Check belt tension by squeezing belt. Proper tension will allow deflection of 1/2 to 3/4 inch. To increase or decrease belt tension, loosen bolt in slot of motor support bracket. Adjust belt to proper tension and retighten bolt.

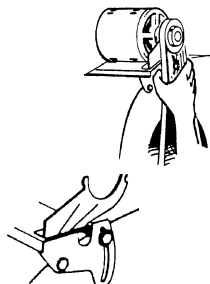

Do not tighten belt by adjusting motor pulley.

Connect Water Supply

CAUTION: All plumbing installations must comply with local building and safety codes, and must be performed by qualified personnel only.

NOTE: Coolers should not be connected to "soft" water systems. Soft water will accelerate corrosion and decrease the effective life of pads and cooler cabinet. Connect water line as follows:

- A water supply valve should be installed at a convenient location, to allow the water supply to be turned on and off for servicing or winterizing. Minimum 1/4" diameter tubing should be used to provide water to the cooler, larger tubing is recommended if the distance from the valve to the cooler is greater than 100 feet, then reduced to 1/4" at the unit.
- Install float valve through the hole in the side panel opposite the pump.
- Connect tubing from water supply to float valve. Place compression nut and ferrule over end of tubing, insert tube into float valve then tighten compression nut to secure.

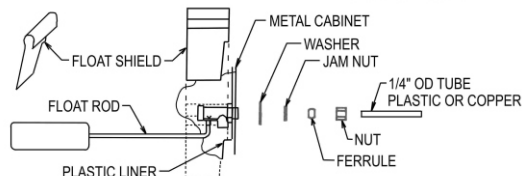

Install Overflow Standpipe / Drain Line

Install overflow drain bushing in bottom of cooler as follows:

- Slide rubber washer over drain bushing.
- Push drain bushing through bottom of cooler, assemble and tighten lock nut.
- Screw plastic overflow standpipe into the drain bushing and tighten snugly (hand tight) to prevent leakage.
- Connect a suitable drain line (copper / PVC / garden hose) to drain bushing. Avoid draining water onto a roof; mineral build-up or damage to roof may occur.

NOTE: Drain water in accordance with local plumbing codes.

Install Pro Cleaning System (PCS)

To minimize mineral scale "build-up", your cooler has a PCS assembly pre-installed. The PCS will drain the cooler water every 5 hours of operation, allowing the cooler to refill with fresh water. To complete the installation, find the pump plugged into the receptacle marked 'DRAIN PUMP' and insert the end of its water hose to the overflow standpipe, using the drain adapter fitting. Avoid kinking the water hose.

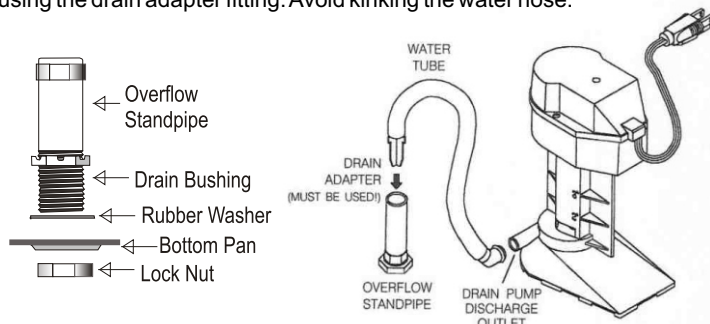

Adjust Motor Pulley

When the cooler is connected to extended ductwork, the cooler capacity and motor amperage may decrease due to the increased duct resistance. The adjustable motor pulley is to be used ONLY to return the cooler motor to its maximum allowable amperage and should not be readjusted except for this purpose.

CAUTION: Do not exceed the maximum motor amperage (FLA) stamped on the motor specification plate or motor can be overloaded, damaging motor.

Check amperage with all doors, windows and exhaust vents open and/or all relief systems operating.

Improper pulley adjustment will overload and severely damage motor windings (this damage will NOT be covered under warranty). Only qualified persons with proper electrical equipment and knowledge should adjust variable pitch motor pulleys.

CAUTION: Never operate unit with access panels removed. This will result in an overloaded condition and may damage the blower motor.

GENERAL INSPECTION

Initial Start-up or Annual Inspection

CAUTION: Disconnect all electrical power to the cooler before attempting to install, open, or service your cooler. If the cooler is thermostatically controlled, the thermostat is not to be used as the power supply disconnect, as it may reset and start the unit unexpectedly.

Before start-up of the cooler for the first time, or at the beginning of each cooling season, make sure that all required connections, adjustments, etc. have been made. Verify that:

- ✓ Cooler mounting is level; ductwork is sealed.
- ✓ Cabinet is securely fastened to mounting.
- ✓ Cooler cabinet is properly grounded. Electrical connections are correctly made, safe and secure.
- ✓ Motor, pump, drain, float valve, etc. are correctly installed and fully functional.
- ✓ Water line securely connected, turned on, no leaks noted.
- ✓ Float adjusted for proper water level.
- ✓ Pump impeller turns free and smooth. If in doubt, remove impeller cover (see "Cleaning Pump") and check rotation.
- ✓ Blower wheel, shaft, pulley and motor sheave bolts / setscrews are tight.
- ✓ Motor sheave / Blower pulley alignment okay; belt correctly tensioned, blower wheel turns freely.

Start-up Check List

CAUTION: Never operate cooler with access panels removed. This will result in an overloaded condition and may damage the blower motor.

To verify and check out the cooler installation on initial or annual start-up, the following procedure should be followed.

- ✓ Turn electrical supply to pump on.
- ✓ Verify that pump starts and pads are evenly wet.
- ✓ Open building exhaust / relief vents (windows, doors, etc.)
- ✓ Turn electrical supply to blower motor on.
- ✓ Observe that motor starts and runs, check each speed (where applicable) and confirm air delivery.
- ✓ Verify motor amperage does not exceed nameplate.
- ✓ No leaks from water lines, cabinet, etc.
- ✓ Cooler pads: even wetting, no dry streaks.
- ✓ Confirm water level depth setting is correct.
- ✓ Blower wheel / motor rotates freely, no unusual noises.
- ✓ Belt condition / tension / alignment OK.

In case of trouble on any of these steps, refer to the Troubleshooting Chart on page 6.

MAINTENANCE SCHEDULE

Regular maintenance and periodic inspection is the key to long and successful service from your Pro-series cooler. The cooler should receive major servicing at least once a year, more often if conditions require (dusty environment, constant use, poor water quality, etc.) For maximum cooling efficiency, long life and appearance, every two months during operation, the cooler should be inspected and cleaned.

NOTE: Do Not Undercoat the Water Reservoir

The parts of your cooler that are in contact with water are protected by plastic liners. The plastic surfaces should be very easy to clean, but care must be taken to avoid damaging them. All foreign materials, mineral scale, hard water deposits, dirt, etc. should be removed from plastic liners, water pan and other components by using warm water and a soft cloth. Use of any asphalt 'cooler coats' or other types undercoating may damage the plastic and will void your warranty.

NOTE: Do not use cooler cleaners, cooler treatments, anodes or other chemical additives in this evaporative cooler. Use of any additives or water treatment other than the furnished bleed-off will void your warranty and may impair the life of the cooler.

Before starting any maintenance operation, thoroughly read all operating and maintenance instructions and observe all cautions and warnings.

Cleaning

CAUTION: Never wash your cooler cabinet with a garden hose; water may harm motor and pump or seep into ductwork. Motors damaged by water are NOT covered under warranty.

All foreign materials, mineral scale, hard water deposits, dirt, etc. should be removed from pad frames, water pan and other components. Your cooler's long lasting finish can be brought to like-new condition by using warm water and a soft cloth.

Maintenance & Inspection

IMPORTANT: Before operating cooler at the beginning of each cooling season, turn blower wheel, cooler motor and pump motor shafts by hand to make sure they turn freely. Failure to do so may result in burning out motor.

Periodic inspection of your cooler will enhance the chance for long, trouble-free service life. For maximum efficiency, every two months during operation, or any time the cooler is opened, the cooler should be inspected. Some suggested items to look for:

- ✓ Check for leaks from water lines, cabinet, etc.
- ✓ Any dry spots or streaks on pads when pump is operating?
- ✓ Are bolts, nuts and set screws still snug?
- ✓ Are the bearings, etc., making any unusual noises?
- ✓ Does the blower wheel turn freely?
- ✓ Is float level set correctly?
- ✓ Is water in the bottom pan clean?
- ✓ Belt condition / tension / alignment OK?

Adjust Belt Tension

Each time you inspect your cooler, be sure to check belt tension on motor and blower assembly. Check belt condition and replace it if frays or cracks appear. Check alignment of blower pulley with motor pulley (see page 4 for detailed steps).

Draining

Drain the cooler (with power off and pads removed) as follows:

- Connect a drain hose to the drain fitting on the bottom of the reservoir, if not already connected to drain line.
- Remove overflow standpipe from the drain fitting.
- Drain and clean reservoir (avoid draining water onto a roof, mineral build-up or damage to roof may occur).

Cleaning Water Pump & Hose

CAUTION: Disconnect all electrical power to the cooler before attempting to install, open, or service your cooler. If the cooler is thermostatically controlled, the thermostat is not to be used as the power supply disconnect, as it may reset and start the unit unexpectedly.

CAUTION: Do not allow pump to fall over and become submerged; water will damage pump motor.

Clean water pump and hose assembly as follows:

- Unplug pump cord, remove mounting bracket screw and remove pump from cooler. Shake gently to remove water.
- To prevent breakage, carefully release the snap-out impeller cover plate and remove cover plate from the pump body.
- Using a mild detergent solution and a soft cloth, clean deposits from screen, around impeller and cover plate. Spin impeller to dislodge any remaining foreign material.
- Remove any foreign material in the hose adapter (between the pump and hose), or between the hose and the water distributor assembly.
- Rinse and reinstall impeller cover plate.
- Reinstall pump and reconnect pump cord.

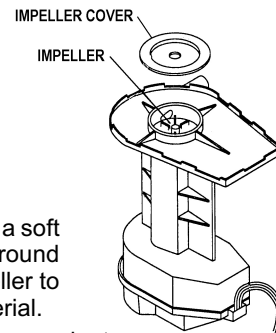

Touch-Up

The hardness, adhesion and smoothness of our Peblar XT® appliance-type finish on the internal and external surfaces of your cooler makes it extremely unlikely that scratches or chipping will occur. Your cooler's long lasting finish can be brought to like-new condition by using warm water and a soft cloth.

NOTE: Avoid using scouring pads, steel wool or wire brushes, as these will damage the finish and encourage corrosion.

In the event that finish damage does occur, it should be promptly repaired by the following procedures:

1. Sand the area around bare metal spots.
2. Prime and paint with a quality paint.

Do not use asphalt type cooler undercoat material in water reservoir.

Lubrication

Motor Bearings

Some motors used in Pro-series coolers have ports for lubricating the motor and are oiled at the factory. If the need for oiling is indicated, see individual motor nameplate for specific instructions on re-lubricating the motor. Under normal use, these motors require oiling about every 12 months of operation. **Do Not Over-Oil.**

Blower Shaft Bearings

Blower shaft bearings need periodic lubrication. They should be checked 20-30 days after initial start-up of operation. The oil cups on the bearings should be filled with a good grade of SAE 20W or 30W non-detergent oil when necessary. Under normal use, oiling is required every three months of operation. **Do Not Over-Oil.**

Pump Motor Bearings

The pump motor does not require lubrication.

Changing Cooler Pads

CAUTION: Disconnect all electrical power to the cooler before attempting to install, open, or service your cooler. If the cooler is thermostatically controlled, the thermostat is not to be used as the power supply disconnect, as it may reset and start the unit unexpectedly.

The condition of your cooler pads should be checked at least once a year; at the beginning of the season is best. However, your pads may need to be checked more frequently, depending on local air and water conditions. Clean or replace pads as follows:

1. Disconnect power from unit.
2. Remove pads from wet section cabinet as follows:
 - a. Remove inlet louver panel, top pan, water distributor cover and tube assembly from cabinet.
 - b. Remove pads by tilting slightly forward and carefully lifting up and out. If passages are clogged or pad is dirty, hose off inlet face of pad. Light, *gentle* brushing of the inlet edges of the pad with a stiff bristle brush (do not use a wire brush) will not harm the pad and will remove more stubborn scaling..
 - c. If necessary, replace with new pads, available from your dealer. Aspen, expanded paper or other types of evaporative cooling pads will not work and will void your warranty.
3. Using a mild detergent, wash dirt and scale from the inside of the wet section cabinet. Wire brushing is not recommended. If finish is damaged or rusting is noted, repair as noted in the "Touch-Up" section. Rinse with fresh water.

4. Reinstall pads, making sure they are positioned correctly (painted stripe on pad placed to the bottom, facing outside).
5. Reinstall water distributor cover and tube assembly, top pan and inlet louver panel.

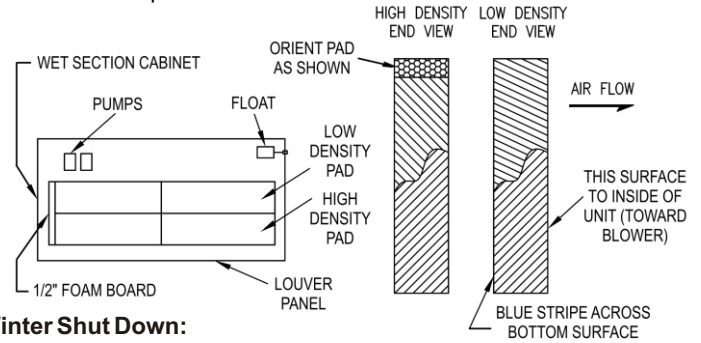

Winter Shut Down:

- *Always* drain all of the water out of the cooler and water supply line when not in use for prolonged periods, and particularly at the end of the season. Keep the water line disconnected from both the cooler and the water supply so it does not freeze.
- *Disconnect* power from cooler during extended periods of non-use.

REPLACEMENT PARTS

When ordering replacement parts, always refer to the serial and model number of your cooler. Use the part numbers listed in the accompanying parts list, as illustrated in the diagrams for your model.

TROUBLESHOOTING GUIDE:

Should an obvious problem occur with your cooler consult the following table. If you cannot correct the problem, or if it persists, contact qualified service personnel.

PROBLEM / SYMPTOM	POSSIBLE CAUSE	CORRECTIVE ACTION
Water draining from unit	Float valve out of adjustment	Adjust float to 2 1/2" water depth
	Float movement obstructed	Free float from obstruction
	Non-functional float valve	Replace float assembly
Dry pads	Pump intake clogged	Remove obstruction
	Non-functional water pump	Replace water pump
	Clogged water line	Locate and free obstruction
	Water distributor clogged	Clear debris from distributor
	Non-functional control or thermostat	Replace control or thermostat
	Non-functional wiring	Repair or replace non-functional wiring
	Water turned off to cooler	Turn on water supply
Motor does not start or no air delivery	Electrical power disconnected	Check power receptacle and cord
	Belt too loose or too tight	Adjust belt tension
	Non-functional motor	Replace motor
	Non-functional control or thermostat	Replace control or thermostat
	Broken belt	Replace belt
Inadequate air delivery	Insufficient air exhaust	Open windows to increase air flow
	Belt too loose	Adjust belt tension or replace is needed
	Pads plugged	Replace pads
Motor cycles on & off	Low voltage	Check voltage
	Excessive belt tension	Adjust belt tension
	Blower shaft tight or locked	Oil or replace bearings
	Bearings dry	Oil bearings
	Motor pulley diameter too large	Adjust to full load ampere rating on motor
	Non-functional motor	Replace motor
Noisy operation	Blower rubbing on housing	Reposition wheel
	Motor sheave or blower set screws loose	Tighten set screws
Excessive humidity in house	Inadequate exhaust	Open doors and windows to increase ventilation