



**Energy Efficiency,
 Exceptional Performance**



Shown with Inlet louvers

Rigid Media Commercial Fan Coolers

Rigid Media Commercial Fan Coolers, in the correct low static application, offer an energy efficient alternative to standard blower wheel units at a fraction of the operating cost. Designed for large areas *with cooling needs to match*, these units can save up to 70% in energy costs.

- 21,600 CFM High Capacity Fan
- 70% Less Energy Costs
- Meets or Exceeds Most Local & National Codes
- U.L. Listed
- 8" Thick Rigid Media

More Air - Less Energy

These highly efficient, commercial grade blades deliver more air while using less horsepower than a comparable sized blower wheel model. Designed for open space applications such as warehouses, factories, manufacturing areas, laundries etc., this specially designed six-blade fan provides the optimum air delivery. Approximately 21,600 cfm at 0.0" static pressure can be obtained using only a 2 HP motor!



U.L. Listed For Safety

These high capacity units are U.L. listed for safety when used in non-ducted, single discharge applications as shown to the left. All units are completely pre-wired with factory installed and tested motor and circulating pump systems. This Phoenix Manufacturing, Inc. unit will meet or exceed most local and national codes.



U.L. Listed when used in non-ducted, single discharge applications as shown.



Economical and Dependable Cooling



U.L. Listed when used in non-ducted, single discharge applications as shown.

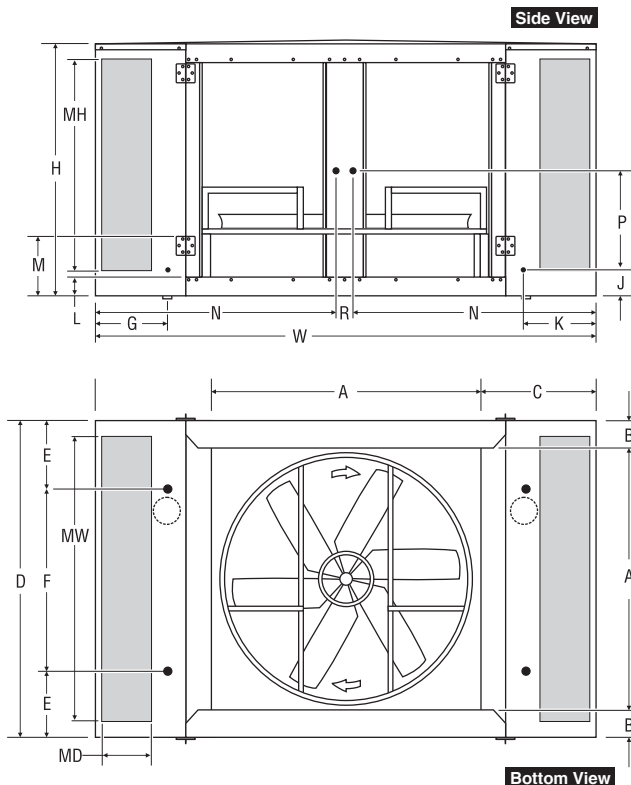

AeroCool Rigid Media Commercial Fan Cooler Features:

- Up to 21,600 CFM Capacity
- AMCA licensed ratings
- Hot dipped galvanized steel construction cabinet
- Peblar XT™ architectural finish, protects against rust
- UL Listed
- 8” thick rigid media

Engineering Data

Model	Fan Dimensions O.D.	Media Dimensions			Cabinet Dimensions			Discharge Dimensions			Drain Location <small>Drains are 3/4" Male hose thread</small>			Water Service <small>Water service opening is 1/4" I.D.</small>		Bottom Pan		Electrical Service <small>Electrical service access 7/8" I.D.</small>			Aprox Weight (LBS.)	
		MH	MW	MD	H	W	D	A	B	C	E	F	G	J	K	L	M	N	P	R	Ship	OPER.
RF42	42	34.5	60	8	39	96	62	46	8	25	13	36	13 1/2	5	13 1/2	3 1/2	12	46 3/8	19 1/2	3 1/4	725	925
RF48	48	44.5	60	8	49	96	62	52	5	22	13	36	13 1/2	5	13 1/2	3 1/2	12	46 3/8	24 1/2	3 1/4	800	1000

AMCA Certified Airflow and Electrical Data

Model Number	Motor Specifications					Pump Volts/Amps ²	Motor ¹ Amperage	Static Pressure (Inches Water) and AMCA Certified Air Flow (CFM)			
	Nameplate HP	BHp	Fan RPM	Voltage	Phase			0.0"	0.1"	0.2"	0.25"
RF4221	2	2.3	592	120	1	120/3.4	18.8	17,800	16,200	13,800	12,400
RF4222	2	2.3	592	208-240	1	120/3.4	10.2 - 9.4				
RF4223	2	2.3	592	208-240	3	120/3.4	6.2 - 5.8				
RF4224	2	2.3	592	480	3	120/3.4	2.9				
RF4821	2	2.3	506	120	1	120/3.4	18.8	21,600	19,600	15,600	13,500
RF4822	2	2.3	506	208-240	1	120/3.4	10.2 - 9.4				
RF4823	2	2.3	506	208-240	3	120/3.4	6.2 - 5.8				
RF4824	2	2.3	506	480	3	120/3.4	2.9				



Phoenix Manufacturing, Inc. certifies that the evaporative coolers shown are licensed to bear the AMCA seal. The ratings shown are based on tests and procedures performed in accordance with AMCA publication 211 and comply with the requirements of the AMCA Certified Ratings Program.

- Performance certified is for installation type B: free inlet, ducted outlet.
- Performance ratings include the effect of evaporative media.
- Power (BHP) includes transmission losses.

1. All external wiring and components such as disconnects, motor starters, and over-current protection are to be field supplied and are not included as part of the evaporative cooler from the factory.
2. A separate 120 volt, 60 hertz, single phase, GFCI protected pump circuit is required to maintain the UL Listing of the evaporative cooler. Pump capacity shown is total for 2 pumps per evaporative cooler.

Phoenix Evaporative Coolers and components are designed and tested in accordance with one or more of the following standards or agencies: **AIR DELIVERY** - data published derived from tests conducted in accordance with A.M.C.A. (Air Movement and Control Assoc.) standard 210. **EVAPORATIVE MEDIA** - specially corrugated cellulose material, impregnated with insoluble antirrot salt and rigidifying saturants. **SEALANT** - water immersion per ASTM D870. **FLEXIBILITY** - per ASTM D756. **CORROSION RESISTANCE** - per ASTM B117. **PENCIL HARDNESS** - per ASTM D3363. **IMPACT RESISTANCE** - per D2794. **FLEXIBILITY** - per ASTM D522. **SPECULAR GLOSS** - per ASTM D523. **SURFACE BURNING CHARACTERISTICS** of building materials (best rating) per UL 723 and ASTM E-84. **PUMPS** recognized under the UL standard #778 for operating water pumps with thermal overload and locked rotor protection. **POLYMERIC MATERIALS** listed in accordance with UL 94 and 746C. **MOTORS** recognized under UL component standard #1004 for motor certification. **MOTORS** tested under UL standard #547 for locked rotor and heat rise protection.



PHOENIX MANUFACTURING, INC.
"Committed to Customer Success"

Phoenix Manufacturing Inc.
3655 East Roeser Road
Phoenix, Arizona 85040
Phone: 602-437-1034
Fax: 602-437-4833
www.evapcool.com